



## 2020 Touring Rules and Regulations

### 1. General Rules

- 1A. Rule Book Disclaimer:** Rules and/or regulations set forth herein are designed to provide for the orderly conduct of racing events and to establish minimum acceptable requirements for such events. These rules shall govern all events, and by participating in these events, all participants are deemed to have complied with these rules. NO EXPRESSED OR IMPLIED WARRANTY OF SAFETY SHALL RESULT FROM PUBLICATIONS OF OR COMPLIANCE WITH THESE RULES and REGULATIONS. They are a guide and are in no way a guarantee against injury or death to a participant, spectator, or official. American Crate All-Star Series (ACAS) retains the right to make all decisions and reserves the right to make any rule changes/amendments without dispute or appeal for the betterment of ACAS.
- 1B. Appeal Process:** By participating in ACAS sanctioned events, drivers forego any right to file any appeal.
- 1C. Series Membership Fee:** \$100 Annual or can be paid in \$25 increments in four consecutive races.
- 1D. Entry Fee:** \$110 Per Race (includes scoring)
- 1E. Point System:** 50, 48, 46, 44, 42, 40, 38, 36, 34, 32, 30, 28, 26, 24, 22, 20, 18, 16, 15, 14, 13, 12, 11, 10 (This will be a standard 24 car field.) From there in the B-main, points will continue for non-transfer cars as follows: 9, 8, 7, 6, 5, 4, 3, 2, 1. (Any remaining cars will receive 1 point.) Only those who pay the \$100 membership fee will earn points. However, those who pay the \$25 temporary membership increments will earn points from the point they start paying and at each event they continue to pay.
- 1F. Awards Banquet:** Drivers/car owners are expected to attend or have a representative attend. If a driver does not send someone to the banquet, he will forfeit all awards/monies. In the event of a tie for any championship, a tiebreaker will be determined by the driver with the most wins, then 2<sup>nd</sup> place finishes, etc. If a tie happens in any other position, the same procedure will be followed. The top 10 drivers will be paid for points as long as they have competed in 75% of the races. This means all race points will be counted when determining

the champion and the rest of the top 10. Rookie of the year: to be eligible to run for Rookie of the Year you must have never run for points with any other crate (or higher class of competition series).

**1G.** Any illegal car or cars will not receive money and points and will be subject to suspension, fine, probation, or all three.

## **2. Event Procedures:**

### **2A. Unacceptable Behavior:**

- 2A1. Fighting or drinking at the event by any driver or crew member will NEVER be permitted. Automatic disqualification will occur on the night of the event; further suspension or permanent expulsion from the series may result as well.
- 2A2. If a driver or crew member enters another's pit area, that team will be considered the aggressor in the situation and will be subject to the harshest of punishments. DRIVERS are responsible for all of their team members.
- 2A3. Random drug testing may be done at any time. Failure of the drug test or to accept the drug test will result in suspension and possibly a fine.
- 2A4. Poor sportsmanship may also result in suspension or fine. Any poor sportsmanship on the track or roughness will result in the removal of the driver performing the act and disqualification for the night.
- 2A5. Refusal to obey officials could result in suspension, fine, probation, or all three.
- 2A6. If a driver gets out on the track for any reason other than safety, he or she will be disqualified. If a driver's crew goes on the track, the driver will be disqualified.
- 2A7. Driving in the pit area must be done at a reasonable pit road speed (Courtesy laps will not start until the driver is in his/her pit area.). Drivers will be subject to penalty for driving too fast.
- 2A8. If a driver intentionally hits another driver's car under caution, hot laps, or in the pits, that driver must pay a \$100 fine (could vary based on the severity of the damage) to the driver he/she hit at that time. This fine must be paid in order to compete with ACAS again.

**2B. Pre-Race:** All drivers are expected to sign in before the race and attend the driver's meeting.

- 2B1. Any driver not attending the driver's meeting will start his heat on the tail.
- 2B2. Drivers must all sign in under their correct names. If a driver finishing the race does not match the signed in name for that car, the driver and car will be disqualified. Official driver changes are allowed if communicated to series officials prior to the change; however, an official driver change will result in the driver starting the tail.
- 2B3. All cars must complete pre-race tech.

**2C. Flags:** The flag meanings are as follows:

- (1) Green - Start the race.
- (2) Yellow - Everyone slow to a safe speed and follow the car in front. Lineups will put all lapped cars to the tail.
- (3) Red - Danger is on the speedway. Stop as quickly as possible.
- (4) Black - Pull into the pits.
- (5) Blue with Yellow Stripe - The car is about to be lapped. "Hold your line."

- (6) White - One lap to go.
- (7) Checkered Flag - The race is over, slow down.

**2D. The Race:** All drivers will compete in optional hot lap sessions, qualifying sessions, dash/heat races, B-mains (if necessary), and features.

2D1. All cars are expected to participate in qualifying. There will be a fast six dash based on the qualifying results. These six drivers will be locked into the top three starting rows of the feature. The dash will be six laps for six racers. The rest of the cars will be lined up in heat races based on qualifying. There will be provisionals held for 23<sup>rd</sup> and 24<sup>th</sup> for participating members of the series only. The first three races of 2020 will use provisionals for 2020 members based on 2019 points.

2D2. On initial starts of the event the race director will start the race at the chalk line, and the leader will set the pace coming to green. It MUST be a consistent pace. Firing before the green flag will result in a jumpstart warning. If it happens again, the driver will be put to the tail and charged with a caution. If a caution occurs before the first lap is completed, everyone will get their spot back, and the race will start again.

2D3. Restarts will be Delaware Double-File through the whole show until the last 5 laps of the feature. The leader will be out front by himself, and the second-place driver will choose inside or outside. From there drivers will be lined up based on what the second-place driver chose. The leader will start the race between turns 3 and 4 in the marked start box. If the leader has not fired by the exit of the start-box, the other drivers may go. If a driver fires before the leader, he/she will be charged with a jumpstart where the same rules apply as on the initial start. If the series deems the track has moved to one groove it reserves the right to make restarts single file.

**2E. Cautions:** The series will enforce a modified no stop rule in the event of a caution. The car who originally stopped and any other car stopping from the initial contact will go to the tail. If a caution comes out because a car is spinning in front of the field, even if the car doesn't stop, that driver will go to the tail. Cars stopping to avoid after the initial wreck has occurred will get their spots back. If it is deemed someone intentionally wrecks another driver that driver will be parked.

2E1. The driver(s) who stopped in the initial incident will go to the tail of the field (or lead lap cars if also a lead lap car) on the restart. Everyone else will get their position back, as long as they do not enter the pit area.

2E2. Series officials will pull sheet metal if it can be done in a reasonable amount of time (30 seconds).

2E3. Drivers in the B-mains and features will be given two laps to go pit-side and change a flat tire or pull sheet metal under a caution.

2E4. If an accident occurs coming to the checkered flag off turn four, the same rules apply as the no stop rule. If the checkered flag flies instead of a yellow, cars involved in the accident will be frozen in their positions from the last lap except for the driver(s) who stopped in the initial accident. The driver(s) at fault will finish as the last car on his lap. If AT ALL POSSIBLE, the yellow flag would wave here instead of a checkered flag.

2E5. Any car that is charged with a caution three times in the feature event will be put off the track. (As long as the black flag is obeyed at this time, the driver will be paid and scored in the position he leaves the track.)

2E6. Any car that goes to the pits for any reason must restart the race on the tail of the field. (The car will be put in front of lap down cars if it is a lead lap car.)

**2F. *Winning the Race:*** The last green flag lap must be completed to be the leader of the race. A green flag lap is considered completed if half the field (rounded down when an uneven number of cars) has crossed the start/finish line when a caution flies. On the final lap of the event, if an accident occurs, racers will race to the checkered flag IF all cars have taken the white flag and IF it is deemed safe by the series officials. (Example: If the accident occurs on the front stretch right after the finish line, a caution will be called for safety purposes.)

**2G. *Payout:*** Tracks are responsible for paying the series the agreed upon payout.

2G1. The series will pay the drivers at the end of the night once the track has paid the series. The track may pay out if they so choose, and a series official will act as a witness when paying drivers of the series.

2G2. All cars that start the feature event will be paid for starting if they are not disqualified from the event.

2G3. Payouts will be held from drivers who have tire samples taken, an engine protested, or any other post-race tech item that requires a waiting period. When test results are returned and if they are in the driver's favor, the driver will be paid.

**2H. *Rainouts:*** We understand every rainout situation will be unique, but generally these rules will apply:

2H1. The series will hold entry fees for the makeup event; if no makeup event is scheduled the entry fee can be used at any race in the next 365 days from the date of rainout.

2H2. All preliminary events through the B-Mains must be completed for a makeup feature only to be scheduled (if possible); otherwise we will restart the show unless event is held over until next day at which point, we will complete the started show.

**2I. *Post-Race Tech:*** Drivers need to be prepared for tire samples, fuel tests, and to remove a valve cover, 2 rocker arms and all spark plugs for post-race engine tech. Tech Directors will be performing a cam check, compression check, valve spring test and P&G post-race. Tech Directors will also spot check using a bore scope to look inside intake manifold and in cylinder. Tech director will take a valve spring sample from the winner, 2<sup>nd</sup>, and/or 3<sup>rd</sup> place cars after each race. Drivers who have a valve spring sample taken will be given one by the series as a replacement. If the sample comes back good the valve spring will also be returned to the driver. All cars are expected to roll through the scales following qualifying, top 3 after the dash/heats, all transfer cars plus 1 after the B-Main, and the top 5 after the feature. \*Head Technical Inspector reserves the right to determine all post-race tech inspections. Decisions are his alone and final.

### **3. Technical Rules:**

**3A. *Engines:*** GM part number 19258602 or 88958602 and GM part number 19318604 or 88958604 are the only engines that will be permitted to participate in the series.

3A1. All engines and parts must be as from factory and all components thereof. All engines are to remain sealed from the factory. These engines are sealed at the intake manifold, cylinder heads, front cover, and oil pan with special GM twist-off bolts or with the cup style seals.

- 3A2. Any “unauthorized” changes will result in disqualification, no points, fines, and other possible penalties including, but not limited to, being barred from ACAS sanctioned competition. This includes, but is not limited to, harmonic balancers, valve springs, push rods, rocker arms, aftermarket valve covers etc. Tampering, removal, or modifications of any type and/or broken, tampered factory seals will not be permitted and will result in immediate disqualification from the event. The engine may be impounded immediately for further inspection.
- 3A3. The only exception will be if a repair or rebuild is required. The repair/rebuild must be authorized by the American Crate All-Star Series, at which time the engine may be repaired or possibly rebuilt per the guidelines set forth in the GM Technical Manual #88958668. Crate engines must not be altered, modified, or changed from factory specs.
- 3A4. Engines **MUST** be sealed in all of the above stated locations with either the **original** New GM seals, FASTRAK seals, SECA seals, or Nesmith Crate racing gen IV (green), gen V (black), seal tags, RUSH and UCRA std. Any other series seal that allows no changes within the bolts may be considered legal. (No RM, UCRA .020, counterfeit or eBay bolts will be allowed.) The ACAS reserves the right to tear down any engine following any event.
- 3A4a. Old style GM Twist bolts or Crate Racing Gen III (yellow) bolts may be run, but if they finish in the top three of feature event, they are subject to a tear down at the driver’s expense.
- 3A5. The sealed engines must remain intact and not be tampered with; any seals that have been tampered with, removed, modified, and/or broken will make the engine illegal and result in immediate disqualification from the event (loss of points and money). The engine may be impounded immediately for further inspection. Modifying any internal engine parts or changing the parts from stock as delivered sealed from the factory will result in disqualification for the night’s event (loss of points and money).
- 3A6. The permitted GM factory sealed crate engines must not be altered, modified, or changed from the GM specifications in the GM Technical Manual #88958668; no changes at all are allowed to the engine - intake, manifold, valve covers, heads, front cover, oil pan, harmonic balancer, or any other part or parts on or in the engine.
- 3A7. **We will allow Clevite P series rod, main and cam bearings. Aftermarket valve cover gaskets and breathers will be allowed.**
- 3A8. Engine Setback: 25 ½ inches (measured from center of ball joint to front of engine plate).
- 3A9. *Engine Protest Rules:*
- 3A9a. Top 5 main event finishers may protest any Top 5 finisher in front of them. The protested driver may counter protest within 5 minutes of being notified of protest. All protests must be made to ACAS officials by the driver. Driver must have cash in hand. Claim fee must be paid within 5 minutes of protested car crossing scales.
- 3A9b. Engine Claim Rule: Drivers may claim another’s GM 604 for \$6,200. When claiming an engine, the driver will only receive it as delivered from GM with no accessories, distributor, wires, carburetor, pumps etc.
- 3A9c. Complete Engine Protest Rule: The protest fee is \$1,200. The winner of the protest receives \$1,000, the series receives \$100, and the ACAS selected technical inspector receives \$100. If the engine is found illegal, the protester

will receive their money back, and the protested driver will have to pay the \$1,200 fee to get the protested engine back. In the case of a full engine protest, the series representative will claim the entire engine and meet at a selected technical inspector's business at the appointed inspection time. If a driver is found to be cheating a \$1,000 fine will be levied on the driver, and the driver will be banned from any ACAS competition for 365 days. The \$1,000 fine will be paid in addition to the \$1,200 fee to get the engine back.

3A10. Valve Spring Specifications: **No PAC Springs**

3A10a. Valve Spring Protest: Protesting of the Valve Spring is \$200 and must follow the same procedures as protesting an engine. ACAS will provide protested driver with a Valve Spring. If found legal, legal valve spring will also be returned to the driver. Please see rule 3A9.

3A10b. (Valve Spring Penalties based on 365-day period from time of infraction.)

**1<sup>st</sup> Offense:** \$200.00 fine, loss of points, loss of prize money, and 25-point deduction to year end points total.

**2<sup>nd</sup> Offense:** \$350.00 fine, loss of points, loss of prize money, and 50-point deduction to year end points total.

**3<sup>rd</sup> Offense:** \$500.00 fine, loss of points, loss of prize money, and suspension to be set at ACAS discretion.

Valve Spring Specifications – Old (non-beehive)				
Description		88958602	88958603	88958604
Valve Spring P/N		10212811	12551483	12551483
Valve Spring P/N -set of 16		n/a	12495494	12495494
Diameter (+/- .010")	(A)	1.250"	1.340"	1.340"
Free Height (+/- .015")	(B)	2.021"	2.154"	2.154"
Installed Height (Ok to shim to proper height)	(C)	1.70"	1.780"	1.780"
Pressure @ Installed Height (+/- 5 lbs)	(D)	80 lbs.	110 lbs.	110 lbs.
Open Height	(E)	1.270"	1.300"	1.300"
Open Pressure (+/- 10 lbs)	(F)	195 lbs	270 lbs.	270 lbs.
Coil Bind	(G)	1.20"	1.21"	1.21"
Wire Diameter		.177"	.178"	.178"

Blue Beehive Valve Springs:

Valve Spring Specifications – New (Blue) Beehive Valve Spring		
Description	Engine	
CT 400 Engine		88869604
Valve Spring P/N -16		12499224

Valve Spring P/N		12625033
Diameter Top (+/- .010")		1.060"
Diameter Bottom (+/- .010")		1.270"
Free Height (+/- .015")		2.122"
Max solid height		1.210
Min Installed Height (Ok to shim to proper height)		1.780"
Pressure at installed ht ( + 5 lbs tolerance )		98lbs
Open Pressure (+/- 13 lbs)		267 lbs.
Wire diameter (Ovate)		(.168" x .211")
Retainer. 19303149		11.9g
Keeper. 19302868		3.9g

**3B. Weight:** GM 602 Car and Driver (2200) and GM 604 Car and Driver (2300).

3B1. The top 5 cars will weigh after each feature before going to victory lane or the trailer. If a driver chooses to weigh outside the top 5 and is light, he will be disqualified.

3B2. After qualifying every car must cross the scales. The top three must cross after the heat. All transfer cars plus one from the B-main and top five after the feature will also cross the scales.

**3C. Carburetors:** One four-barrel carburetor only of any brand is allowed. The engine must be naturally aspirated.

3C1. Carb spacers for 604 (must be flat on top and bottom) - 1" spacer maximum with a .040 tolerance

3C2. Carb spacers for 602 (must be flat on top and bottom) - 2" spacer maximum with a .040 tolerance

3C3. One gasket per surface .070 maximum.

**3D. Transmission:** Bert, Brinn, or Falcon type transmissions allowed. It must have a working clutch with forward and reverse gear. Drive shafts should be painted white with car number. This is a safety issue! Drive shaft loop is highly recommended. Air shifters not allowed. Carbon fiber, aluminum, or steel drive shafts permitted.

**3E. Fuel:** Drivers must claim the type of fuel they are using for a comparison test.

3E1. Fuel tests may be performed during post-race tech or sent to the labs for testing. Any suspicious fuel will then be sampled and lab tested. Additives that will be tested for but not limited to are nitromethane, propylene oxide, alcohol (all types), aldehydes, aminobiphenyl, benzene, borane, benzidine, beryllium compounds, bromine compounds, butadienes, chlorinated compounds, chromates, dioxane, MTBE, ethyl acrylate, ethylene oxide, hydrazine compounds, dioxane, methylenedianiline, naphthylamine, nitrogen compounds, styrenes, toluidine, and xylydine. Any of these compounds that are not included in fuel claimed or in correct amounts matching benchmarks will be deemed illegal.

3E2. A hydrometer test may be done with a .770 Max for E85. .750 Max for gasoline.

3E3. E85 may be water tested with an 85% CONTENT plus or minus 3%

3E4. Fuel protests cost \$150 and will be sent to the lab. See tire penalties below. The same penalties will apply to fuel found to be wrong.

3E5. Fuel Systems: Mechanical fuel pumps only. No electric fuel pumps of any type will be allowed. No nozzles, etc. may be connected to the fuel system at any point. Only one fuel system per car is permitted.

**3F. Evacuation Systems:** Evacuation systems are not allowed. This means any type of vacuum system; includes vacuum from that of breather system and/or any other means of pressure evacuation from crankcase.

**3G. Oil Pump/Pressure:** Oil pumps must be as they come from the factory with the correct engine/oil pump combination (therefore the 602 Oil Pump is not legal on a 604). The original stock GM spring may not be altered from the factory with no additional shims. Wet sump only. No external oil pumps (even if considered “wet”). Remote oil filters and lines are permitted. One remote oil filter is allowed. One oil cooler is allowed. For a 604, anything over 48 lbs at 1800 rpm after qualifying may be subject to additional inspection. Lifters may not be altered in any manner and must be as they are from the factory.

**3H. Distributor:** Any electronic ignition is allowed. No crank trigger, no distributor-less multi-coil, no magneto systems, also no traction control devices are allowed.

**3I. Starter:** Cars must all have a starter that is in proper working order.

**3J. Water Pumps:** Water pumps may be cast iron or aluminum. No electric water pumps or fans will be permitted.

**3K. Headers:** Collector type headers are required. You must have four tubes into one collector. No merge collectors. No tri-y headers.

**3L. Exhaust:** Mufflers are permitted but are not required unless the event is at a track where the track has a noise ordinance.

**3M. Brakes:** All cars must have operational 4-wheel braking systems. An electric or manual proportioning valve is permitted. Carbon fiber, titanium, or other exotic materials are not legal. Brake rotors must be magnetic.

**3N. Electronic Devices:** No electronic devices thereby enhancing adjustment of a car is allowed.

3N1. Traction control is NOT legal.

3N2. Remote-control devices are not allowed at any time.

3N3. No electronic devices controlling shocks are allowed.

3N4. Exotic materials (titanium, carbon fiber, tungsten, etc.) are illegal.

3N5. Carbon fiber drive shafts are legal (for safety purposes).

3N6. No electronic devices that transmit voice or data are allowed at any time.

3N7. Adjustable restrictor plates are not allowed.

3N8. No data systems will be allowed. The same penalties that apply to tire infractions will apply here.

3N9. Go Pros or other similar cameras will be the only type of electronic devices permitted at all on the car and this is only as long as it doesn't interfere with either the transponder or Receiver.



3N10. Receivers: It is the driver's responsibility to have a working Receiver. It is NOT THE RESPONSIBILITY of the series to make sure a driver has working batteries. If a driver's Receiver is not working or he is not wearing it, he will be put off the track.

3N11. Transponders: Any transponders owned by the driver are their own responsibility. If a driver forgets to attach his transponder or it malfunctions, he will not be scored. If a rental transponder from the series malfunctions, he will be scored/allowed to qualify again.

**30. Driver's Compartment Safety:** Window nets, gloves, fire suits, and helmets (with fire resistant interior) are required.

301. Seat belts cannot be more than two years old (There will be a 25-pound penalty if they are.).

302. American Crate All-Star Series Strongly Urges the use of a Hans or Hutchinson (or similar) Device.

303. Drivers must use a quick release steering wheel.

304. Batteries cannot be in the driver's compartment and must have insulated cable ends or plastic covers to prevent fueling fires.

305. Drivers must have either (1) a working fire suppression system or (2) a signed waiver with a working fire extinguisher.

306. A master cut off switch, within reach of the driver, for the car is required.

307. A full containment seat is recommended, or an aluminum or carbon fiber seat with a bolt on head rest will be allowed.

**3P. Wheels:** Maximum 14" steel or aluminum wheels with bead locks are permitted. Carbon fiber or titanium is not legal.

**3Q. Tires:** Open tire rule on the front. Hoosier 1600, Hoosier HTS 1600, LM40, Crate USA D55, American Racer 56s on rear. Grooving and siping is permitted. No chemical alteration. Durometer will be spot checked and suspicious tires will be sampled.

3Q1. Tires may be inspected at any time (numbers, specs, altering, etc.). All tires must have shoulder plates. Tires may be checked by independent lab for treating and other alterations. Tires not conforming to the manufacturer's benchmark will be deemed illegal.

3Q2. ACAS reserves the right to alter tire rules for the standpoint of SAFETY AND LOCAL TIRE RULES. Softening, conditioning, and tires not conforming to manufacture's benchmark are illegal. There are NO appeals and the lab results are FINAL.

3Q3. Protesting of the Tire is \$125 and must follow the same procedures as protesting an engine. Please see rule 3A9.

3Q4. (Penalties based on 365-day period from time of infraction.)

**1<sup>st</sup> Offense:** \$150.00 fine, loss of points, loss of prize money, and 25-point deduction to year end points total.

**2<sup>nd</sup> Offense:** \$300.00 fine, loss of points, loss of prize money, and 50-point deduction to year end points total.

**3<sup>rd</sup> Offense:** \$500.00 fine, loss of points, loss of prize money, and suspension to be set at ACAS discretion.

**3R. Springs:** Only coil springs will be allowed. No pneumatic springs, hydraulic springs, air shocks, or air springs will be allowed. A shock that produces more than 75lbs of rod force when compressed to the center of the shock mounts measurement at the car's static ride height is considered a spring and is illegal.

- 3R1. Coil springs must be made from magnetic steel.
- 3R2. Stacked springs are allowed.
- 3R3. Progressive springs are allowed.
- 3R4. Spring preload adjustments for coil springs must be made using mechanical adjusting nuts on the shock body. No air dumps or hydraulics.
- 3R5. Other than spring damping by the shock absorber, pneumatic, hydraulic, or electrically controlled adjusting devices, (static or dynamic) that affect spring preload or race car heights will not be permitted; air dump devices are not allowed.
- 3R6. Spring rubbers are allowed.

**3S. Bump Stops:** Bump stops are permitted. Bump springs are permitted. No pneumatic or hydraulic bump stops will be permitted.

**3T. Shocks:** One shock is allowed per wheel (except on the left rear where two shocks will be allowed, one in front of the rear end and one behind the rear end). The shocks must be mounted vertical to the axel tube, not horizontal. Shocks, at any position on the race car including lift bar or torque arm shocks, must be made of magnetic steel or aluminum. Thru rod style shocks will not be allowed. Remote reservoirs are allowed. Each shock may have a maximum of two external adjustment mechanisms. The external reservoir can have one external adjustment. The adjuster mechanism cannot be hidden by the rod end. Any and all adjusters must be on the shock body, on the shock rod, or on the remote reservoir. NO cockpit adjustment is permitted.

- 3T1. NO remote adjustment of shocks is permitted, including electronic adjustment of any kind.
- 3T2. Shock absorbers cannot contain any internal spring that functions as a load bearing suspension spring, internal coil bump spring above or below the working piston, nor internal bump stop of any kind.
- 3T3. No air shocks, air springs, or pneumatic springs will be allowed.
- 3T4. Shock covers are permitted, but they must be removed for tech inspections.

**3U. Rear Ends:** Any standard quick-change rear end. No open type (sprint car) rear ends are allowed.

- 3U1. Rear suspension: Standard 4 bar or swing arm rear suspensions only. No spring rods allowed. One shock per wheel except left rear is allowed. Chain limiters are allowed.

**3W. Bodies:**

- 3W1. Rear Deck height measured from ground to the top of the T-Bar is 39" Maximum with driver in car. Rear Deck Height will be measure prior to qualifying if it's off it may be fixed, but only the first lap of qualifying will count. Bottom right front Bumper to ground Maximum 15" high.
- 3W2. See diagram below for remaining body rules.

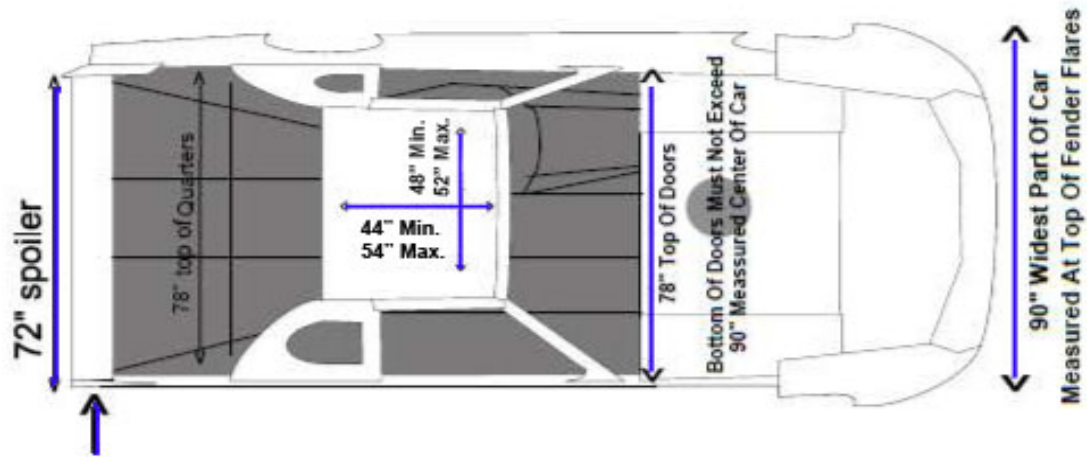

FRONT ROOF SUPPORTS 4" MAX. WITH 12" FLARE MAX. AT BOTTOM.  
 REAR ROOF SUPPORTS OR "C" PILLARS WITH WINDOW OPENINGS  
 ALLOWED BUT MUST BE SAME SIZE OPENING ON LEFT AND RIGHT SIDE,  
 AND CANNOT BE OFFSET. CURVED OR ARCED ROOF SUPPORTS ALLOWED.  
 3" MAX. ARC ALLOWED AT WIDEST POINT, CHECKED WITH STRAIGHT EDGE  
 EXTENDED FROM ROOF EDGE TO DOOR EDGE.

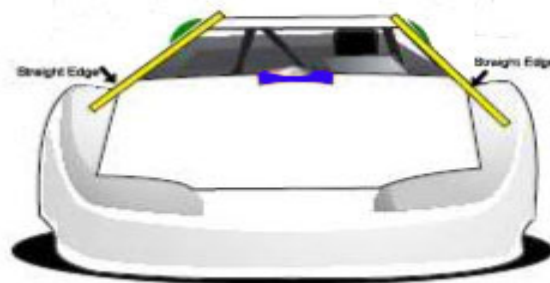
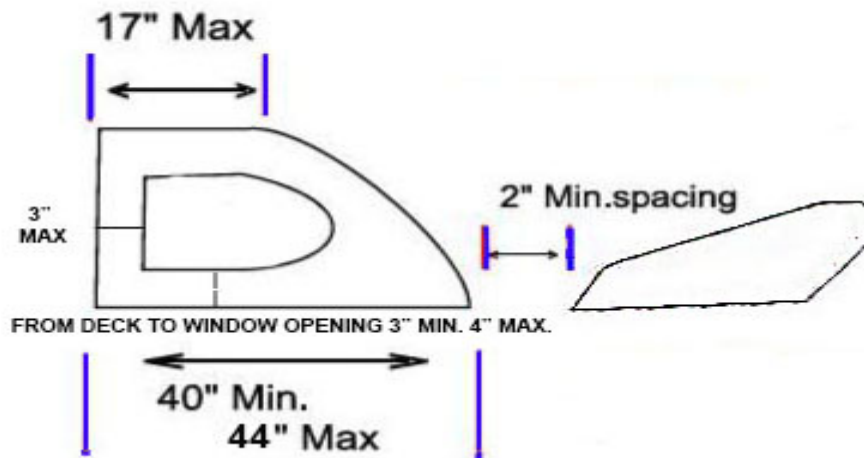

All body components 3" Min. above ground.  
 All body measurements are maximum unless otherwise specified.

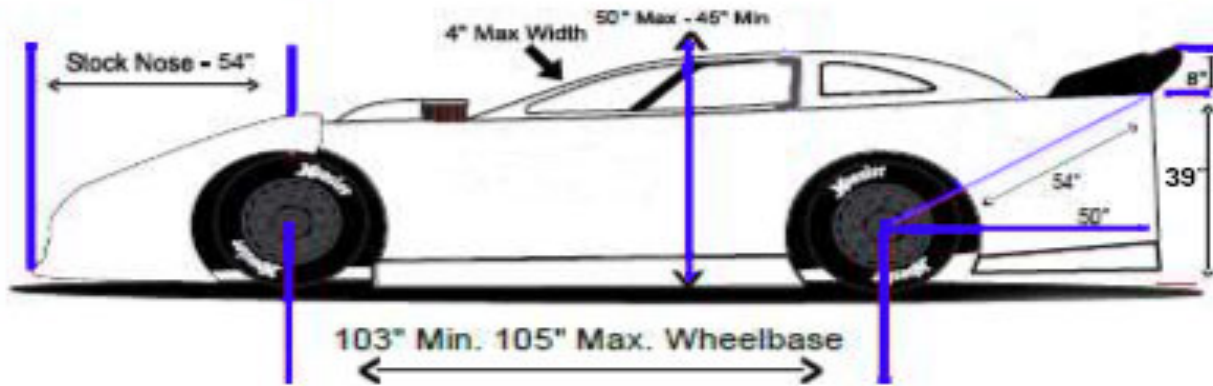

**REAR DECK HEIGHT MEASURED FROM GROUND TO TOP OF T-BAR IS 39" MAXIMUM WITH DRIVER IN CAR. THE MEASUREMENT OF THE SPOILER IS A TOTAL OF ALL MATERIAL INCLUDING ANY TURNS UP OR DOWN AND INCLUDES SUPPORT BRACE**

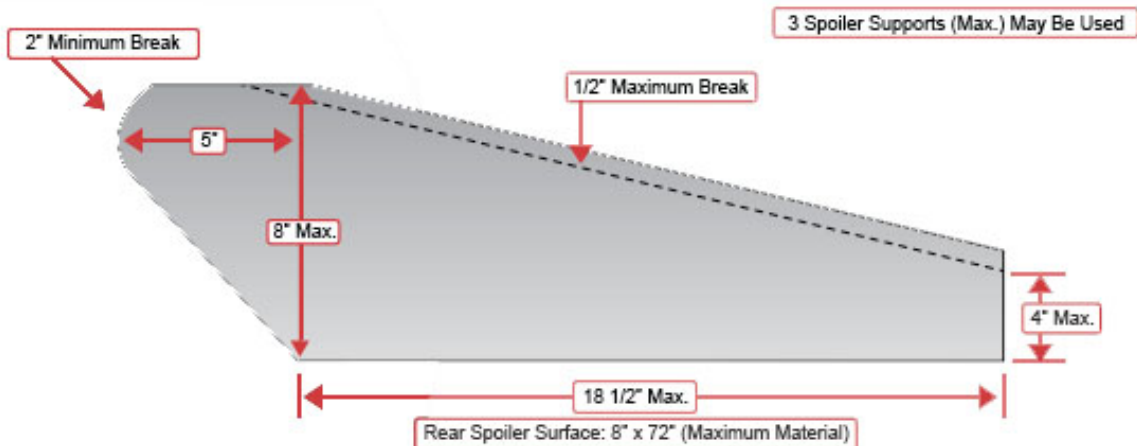

## *Series Staff Contact Information*

Joe Rush  
ACAS CEO  
304-890-3827  
[rushj22@alumni.concord.edu](mailto:rushj22@alumni.concord.edu)

Ryan Atkins  
ACAS Technical Director  
336-401-1422